



Step inside a **Stiltz HomeLift**

Why renovate or move when there's no need to?

stiltzlifts.com



StiltzTM
The **homelift** company

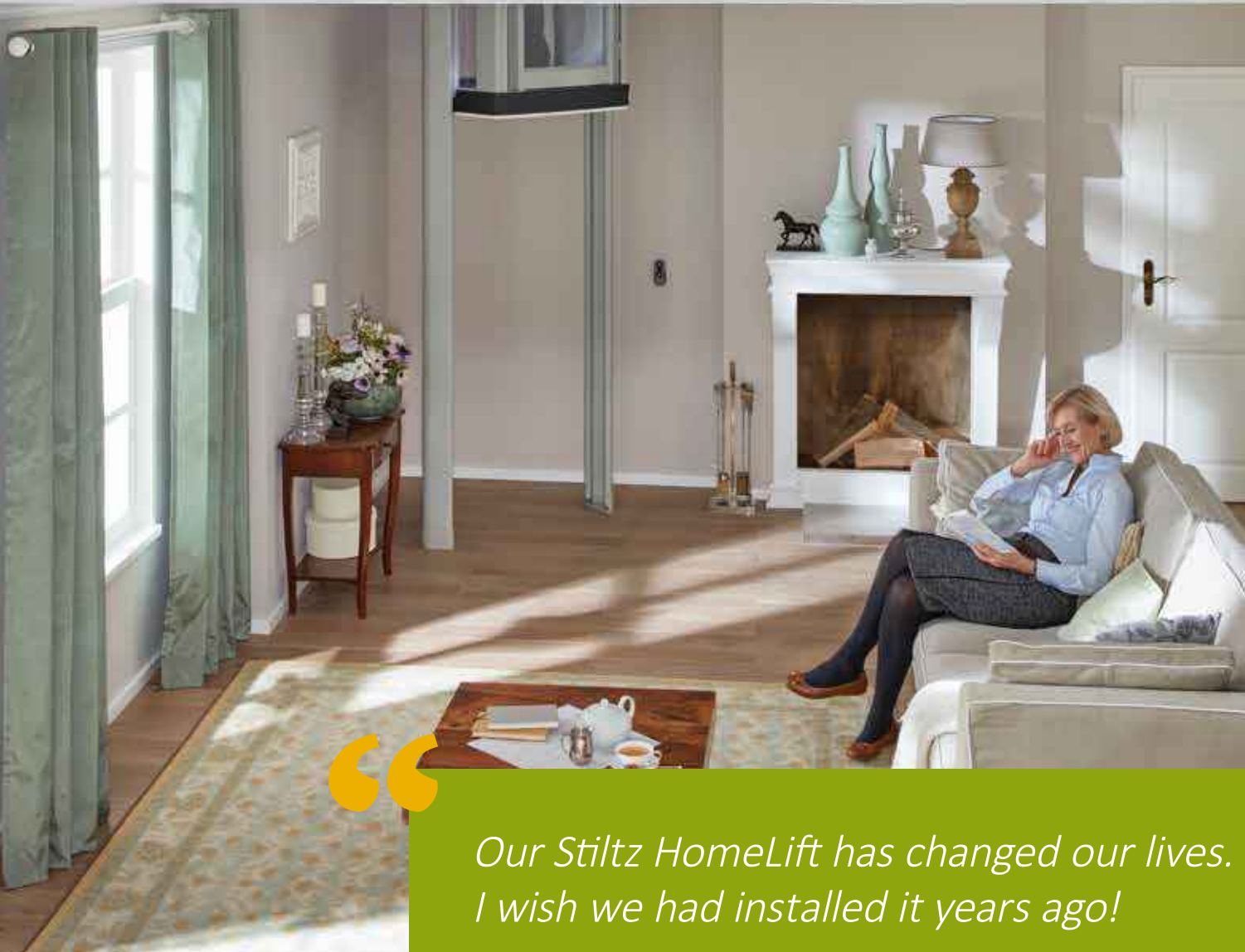

*Our Stiltz HomeLift has changed our lives.
I wish we had installed it years ago!*

Mrs. Ojeda, Florida

With a Stiltz home elevator, you will enjoy every inch of your home — downstairs *and* upstairs!

Why renovate or move when there's no need? A Stiltz HomeLift is the safest, most convenient, most versatile way of getting between floors when stairs have become a challenge.

Look at our unique railing system, and you can tell right away why we're called "Stiltz"! The lift car travels on our unique space-saving rail system, which requires no load-bearing walls.

What's so special about a Stiltz HomeLift?

► **It's safe.**

A battery backup lowers the lift in a power outage. Sensors stop the lift if something is in the way. And a phone is available in case of emergency.

► **It's versatile.**

With different models and sizes, our elevators fit one to three people – or even a wheelchair.

► **It fits just about anywhere.**

Install your lift through the floor, in a stairwell, or up to a landing. No supporting walls required.

► **It's quiet.**

Our electric drive system is very quiet. No noisy hydraulics or vacuum systems are involved.

► **It's an extra pair of hands.**

Comfortably and confidently move laundry, suitcases, vacuum cleaners – even the family pet.

Stiltz empowers people of any age and any ability to stay in the home that they love.





A Duo Alta can be installed almost anywhere. It's so versatile, it can be placed in the corner of a room, tucked in a closet, or run straight up a stairwell void. Alternatively, it can take pride of place in the center of a room or entrance hallway.

And don't worry about operating costs. Stiltz HomeLifts use minimal electricity and can be run off a regular electrical outlet.

Installation is quick and easy. Once the simple construction is complete, your lift can be installed in as little as a day. Your Authorized Stiltz Dealer will then guide you through how to use your lift. Of course, any further help or assistance you may need is always just a phone call away.

DuoAlta

A Compact and Versatile HomeLift

The Stiltz Duo Alta home elevator is designed to make it easier for you to move around the house. Are the stairs a bit much these days? Or are planning ahead by future-proofing? Either way, you'll find that the Duo Alta fits discreetly into any home.



Trio Alta

The Spacious Luxury HomeLift

The Stiltz Trio Alta is a larger home elevator designed to comfortably carry a full-sized wheelchair. The clear body helps it blend into your home, and the unique shape means the rails are discreetly recessed behind the slightly wider entrance/exit.

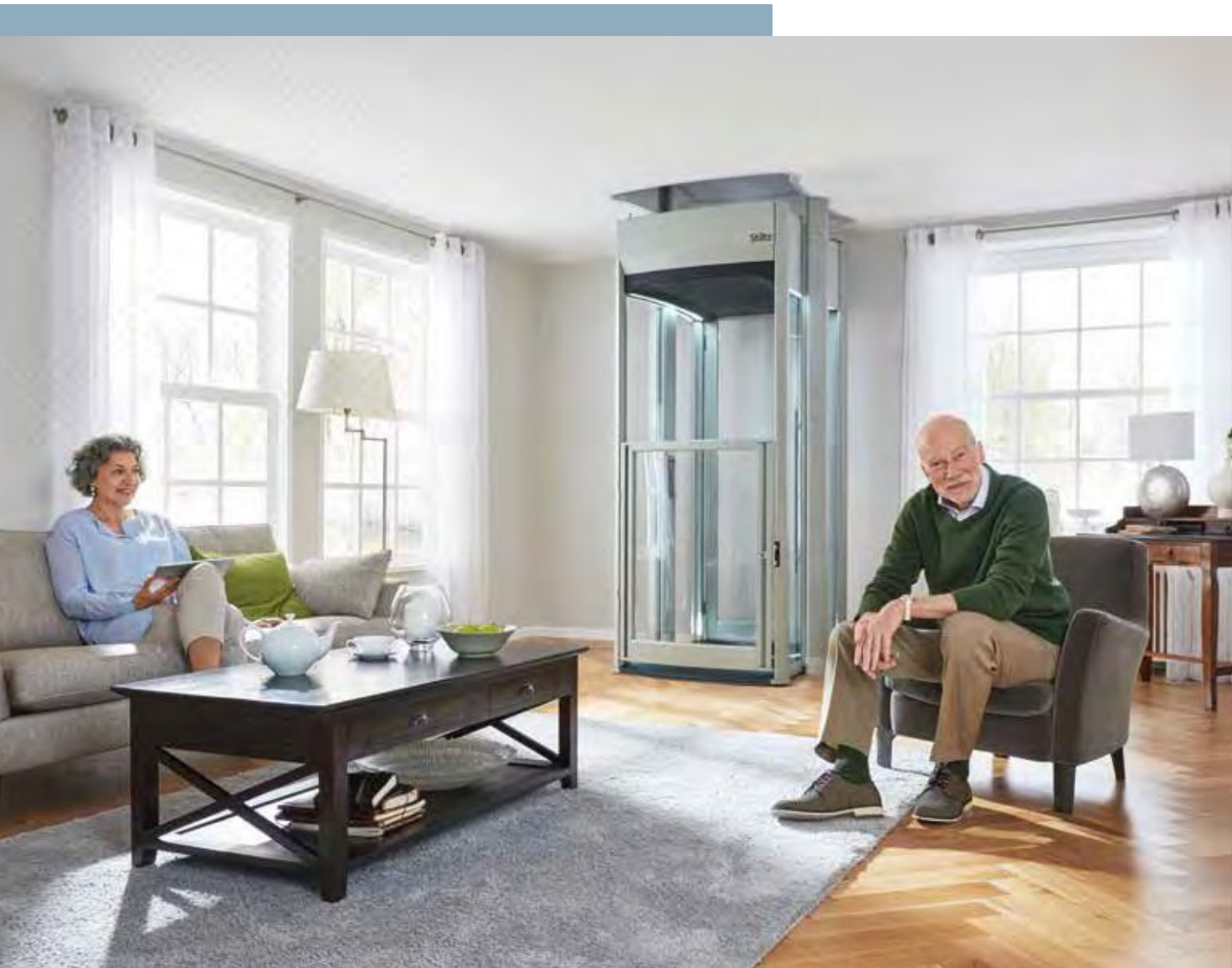

The Stiltz Trio Alta provides more space and luxury. For those who need a larger lift for their home, style and practicality have been perfectly balanced with the Stiltz Trio Alta.

The Trio Alta focuses on size and weight capacity. The Trio Alta can comfortably accommodate a full-sized wheelchair. The gently-angled ramp and wider entrance/exit space make access very simple.

Enjoy the same great features. Just like the Duo Alta, the Trio Alta HomeLift will install quickly without any need for load-bearing walls. It will travel quietly, and use minimal power when moving between floors.

Other Stiltz HomeLift Models



The Classic

The Classic is our entry-level homelift. The original solid-sided model is available as a Duo and the larger Trio lift.

It's a dependable, proven and attractive homelift with a high quality specification and numerous additional options available.



The Vista

The contemporary Vista is available in Duo and Trio sizes. The Duo Vista has a clear lift car body to help it blend into the room where it is installed, and to allow natural light to flood into the lift car. The Trio Vista has a clear back panel, which is ideal if the lift is placed in front of a window.



The Thru-Car

The Stiltz Thru-Car enables you to enter or exit from either side of the lift car. This model is ideal for installation up to balconies or landings, and also where three stops are needed in a bi-level home.

No other homelift on the market is capable of utilizing this Thru-Car configuration – it is unique to Stiltz, thanks to our dual rail technology.

Stiltz HomeLift Footprints

Duo Alta Weight limit 375lb / 170kg

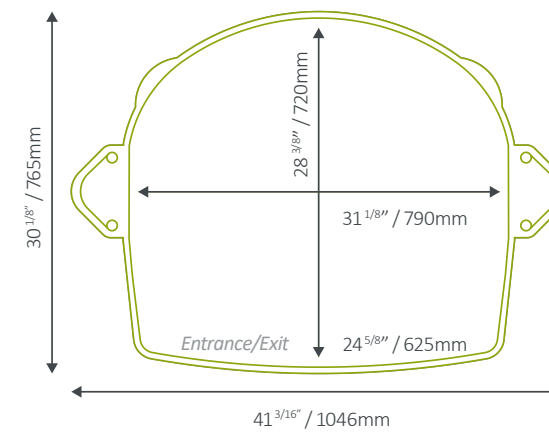

Duo Classic/Vista Weight limit 375lb / 170kg

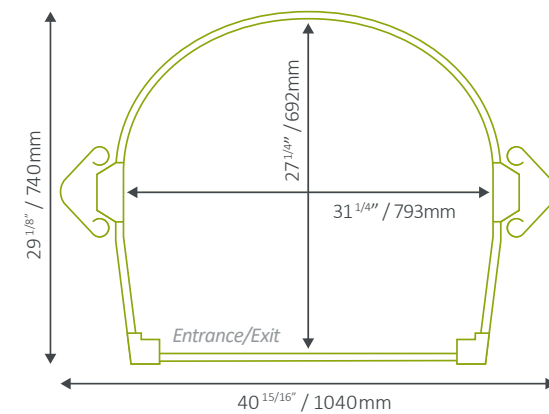

Duo Thru Weight limit 375lb / 170kg

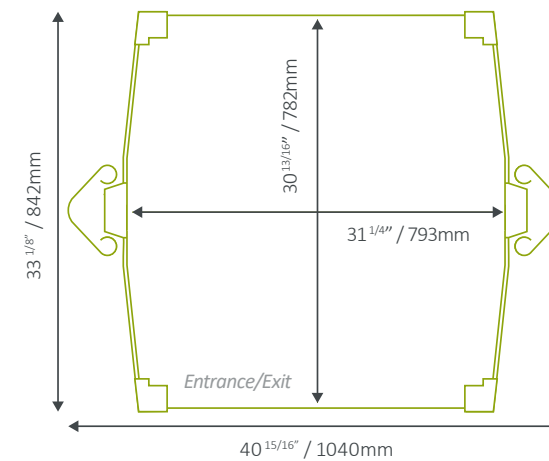

Trio Alta/Alta Thru Weight limit 500lb / 227kg

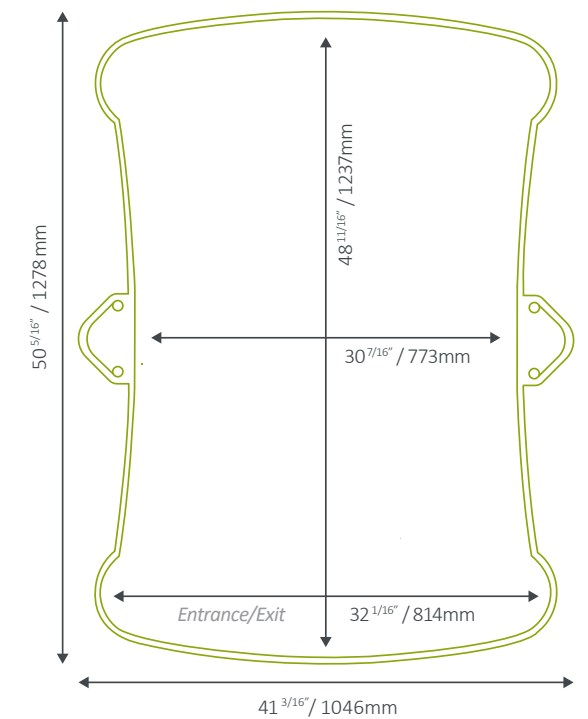

Trio Classic/Vista/Thru Weight limit 485lb / 220kg

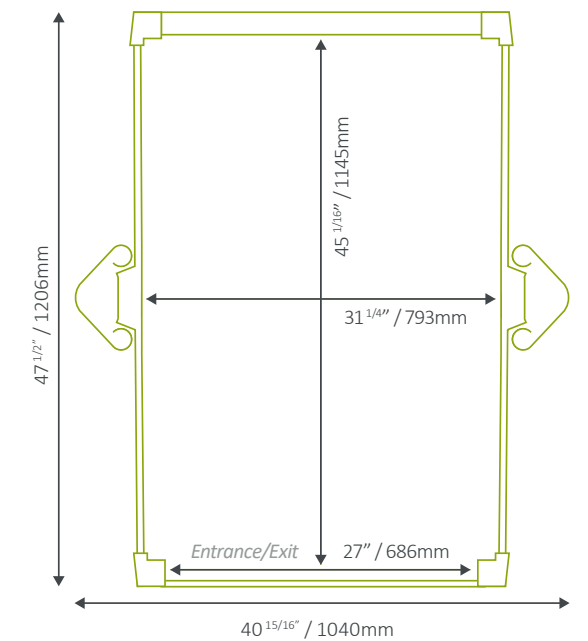

Required upstairs ceiling heights

- Minimum standard upstairs ceiling height for all products other than Trio Alta is 93" / 2360mm.
- Trio Alta requires a standard minimum upstairs ceiling height of 96" / 2438mm.
- All cars can be special ordered with a cab height reduced by 4" / 100mm if required due to lower upstairs ceiling heights.

*Dimensions subject to change.

Stiltz HomeLifts Features & Benefits



Small Footprint

The Duo Alta footprint is a remarkably small 8.5 square feet. The larger Trio Alta footprint can accommodate a full-sized wheelchair and has a footprint of 15.5 square feet.



Full Safety Features

Stiltz HomeLifts are far safer than stair lifts. The lift will not operate when the door is open. Proximity sensors stop the lift if there is something in the path of travel. A battery backup lowers the lift in the event of a power outage. The floor lid is safe to stand on. And a key lock will prevent unauthorized use.



Quiet Operation

Stiltz HomeLifts are powered by a self-contained, electric drive motor — which is completely hidden away in the lift car roofspace. There are no noisy oil hydraulics or vacuum systems.



Fast Installation

Standard installation can take as little as one day, once the ceiling aperture (if needed) has been created by a qualified contractor.



Low Power Consumption

A Stiltz HomeLift plugs into a single, standard electrical outlet — just like any other appliance. When running, it uses very little power.



No Supporting Walls Required

Our self-supporting structure of two parallel, vertical rails — our “stilts” — bear the entire load of the elevator. No additional burden is placed on the structure of your home.



Self-Contained Drive System

Our unique, self-contained drive system is cleverly concealed in a single space within the roof area of the lift car. There’s no need for a machine room or separate oil pump.



Wide Entry

Wheelchair users will find the wide entry and exit points of the Trio Alta particularly useful when maneuvering their chair in confined spaces.



Easy Access

For safety and comfort, the Trio Alta comes with a gently-angled ramp to enable more convenient entry for wheelchair users, and those unable to manage steps.

Why Choose a Stiltz HomeLift?



The “invisible” elevator

Move your lift to another floor — and with only two slim rails remaining, you’ll hardly even notice it’s there.



Small footprints

Both Duo and Trio models have compact footprints — but the Trio Alta will still accommodate a full-sized wheelchair.

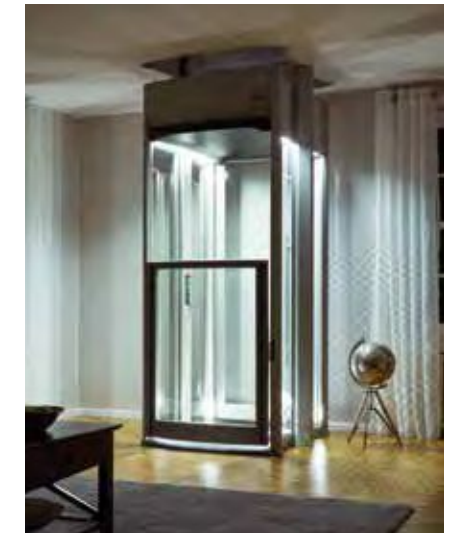

Elegant interior lighting

Subtle and attractive internal lighting means you can travel in comfort and confidence any time of the day or night.



Packed with safety features

Multiple sensors are fitted to every Stiltz HomeLift to ensure that everyone remains safe — both inside and outside the lift.



In-car control panel

The control panel is easy to use, with hold-to-run controls and a key to lock it from unauthorized users, such as children.



Handy remote control

Your homelift comes with two remote control handsets, one for each floor. Additional remotes can be purchased if required.

Many HomeLift Location Possibilities

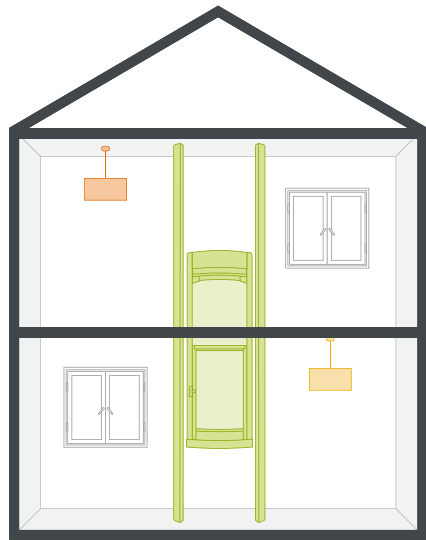

Standard
This is the most common location. The elevator travels through a floor opening from a downstairs room, arriving upstairs (typically in a bedroom).

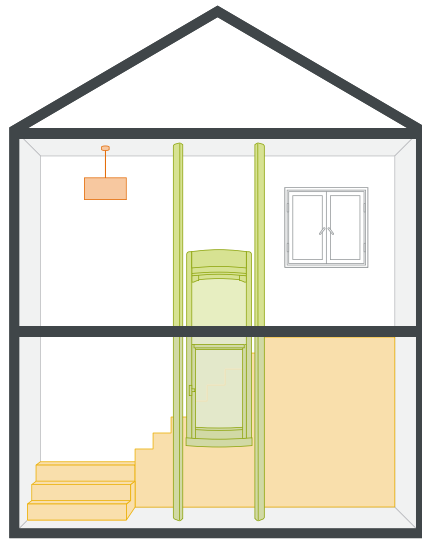

Stairwell Void or Landing
If there is enough room in the turn of a staircase, this location makes use of the “dead space” in a stairwell void. The lift will arrive at an upstairs landing.



Closet
The Stiltz HomeLift is so compact, you can choose to have your lift completely hidden by installing it inside a closet on one or both floors, as layout permits.

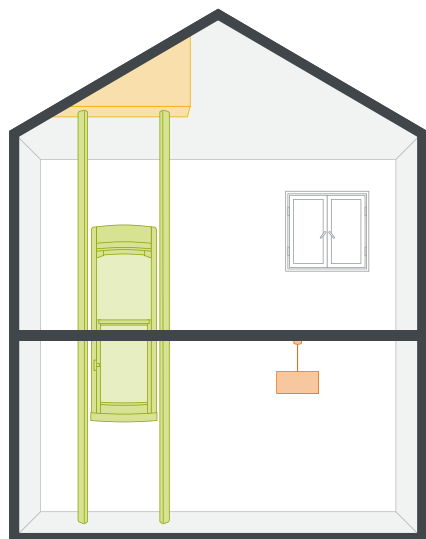

Sloping or Vaulted Ceilings
The lift’s support rails attach to a horizontal surface. But if you have a vaulted ceiling, a contractor will provide a solutions for angled surfaces.

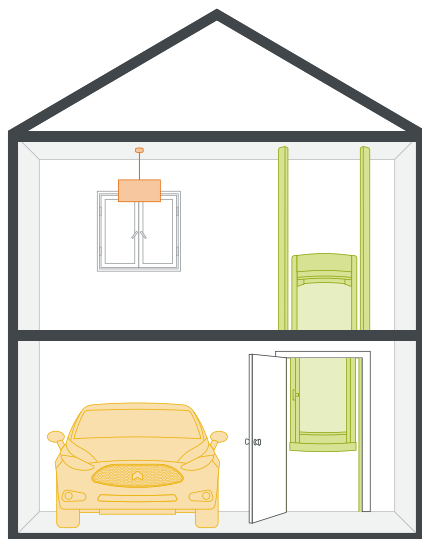

Garage
Get quick and safe access from the garage into your home — great for carrying groceries. (This requires the construction of a simple shaft in the garage.)

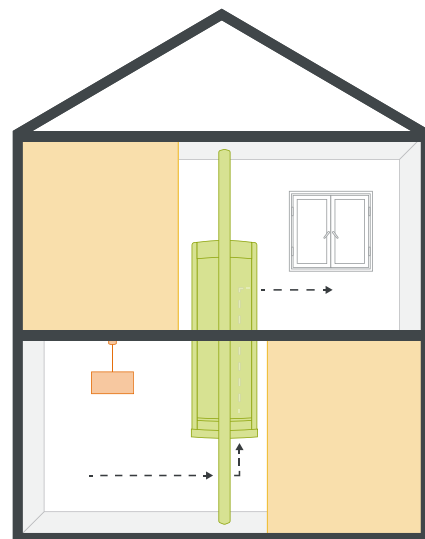

Thru-Car
The Thru-Car, which is unique to Stiltz, lets you enter and exit through opposite sides of the car — ideal for balcony or three-stop lift applications.

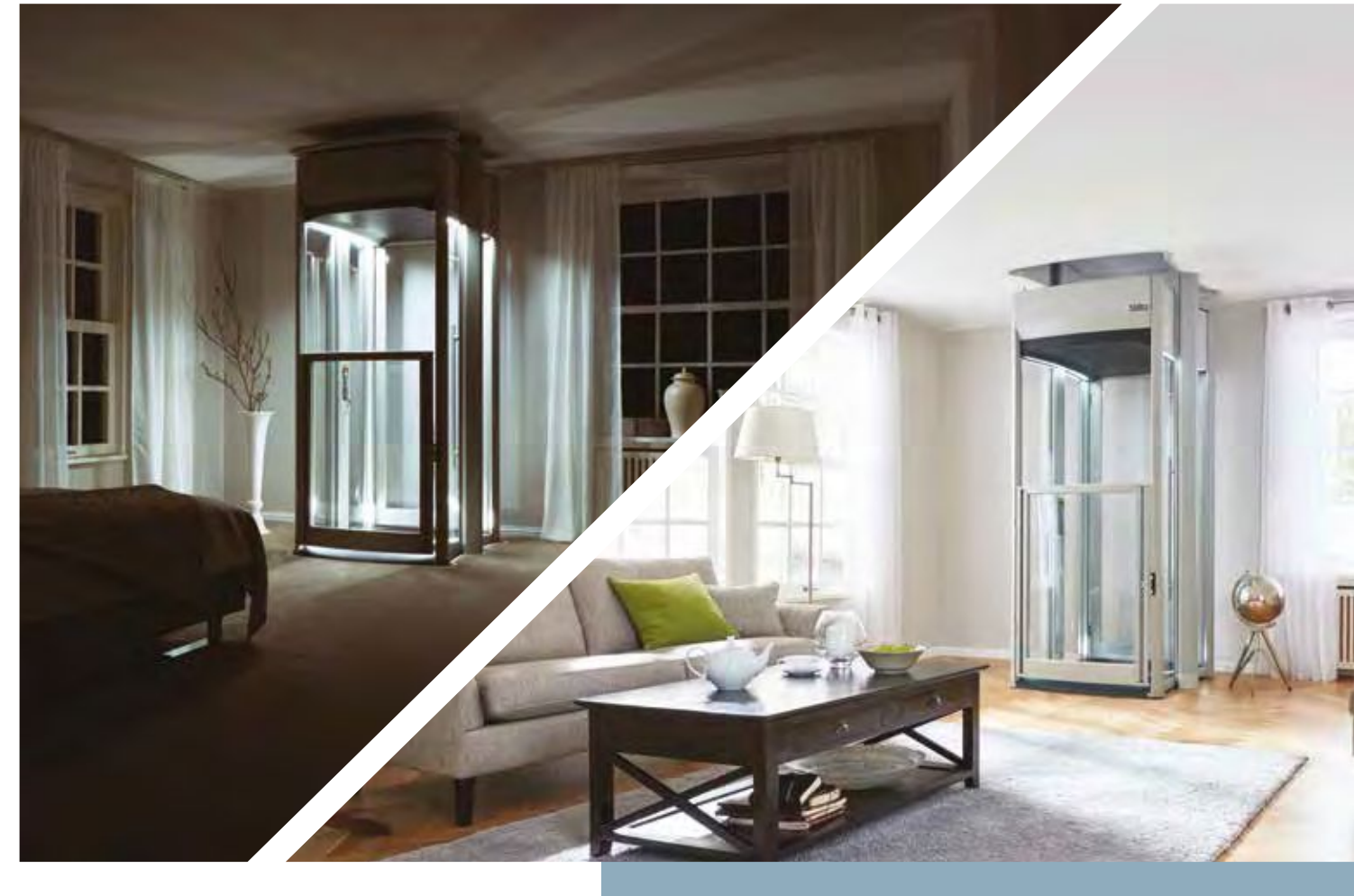

Frequently Asked Questions

► Is a Stiltz HomeLift suitable for wheelchair users?

Yes! The Stiltz Trio Alta HomeLift is ideal for homeowners with mobility issues, because it provides you with the freedom and independence to move around the home unhindered. The Trio Alta is our widest and longest model. It can accommodate two to three people or a full-sized wheelchair. It is the ideal alternative to a stairlift.

► Does the Stiltz HomeLift have a door?

Yes. Stiltz HomeLifts are fitted with your choice of a half-height or full-height hinged door.* The door provides a physical barrier during the operation of the lift. The door locks automatically release when the lift arrives safely.

Lifts with half-height doors come equipped with an infrared “light curtain” that will instantly detect anything crossing over the top of the door. If this happens, the lift will safely stop, and will not continue until the obstruction is removed.

► How safe is the Stiltz HomeLift?

The Stiltz HomeLift has safety sensors above and below the lift car which immediately detect obstructions and stop the car. The lift is also fitted with over weight and out of balance sensors. Finally, every Stiltz HomeLift comes with a built-in telephone — your choice of a landline or cell phone.

► What happens if the power fails and I am in my Stiltz HomeLift?

All Stiltz HomeLifts are equipped standard with a battery backup. In case of a power outage to the home, the battery backup allows anyone in the lift at the time of power failure to gently descend to the lower level of the home, exit the lift, and wait until the power comes back on.

► What kind of construction is required?

It depends on where your homelift is located — but no matter where, construction is minimal. And no supporting walls are ever required. The most common location is through the floor, requiring the appropriate size hole to be cut and finished. Your Authorized Stiltz Dealer will handle this work.

Another common location — through a stairwell void to a landing — needs no hole, but does require a gate at the landing. In rare cases, small amounts of additional work may need to be carried out, such as rerouting pipes or wires — but these are easily managed by your dealer.

► Can I stay in my home for longer with a Stiltz HomeLift?

Yes. A Stiltz HomeLift is a great help to those with mobility problems — but more and more people buy one to “future-proof” their homes while they are still able-bodied. In addition to people, you can carry groceries, suitcases, laundry — even family pets. With a Stiltz HomeLift, you can continue to live a full life in the family home you love for many years to come.

* Your state or local regulations may require a specific type of door.



Our Stiltz Dealer was exceptional. We were very impressed with the installation process.

Mr. & Mrs. Lavdar, Pennsylvania



SUMMIT ELEVATOR

775-360-6464



Our Stiltz HomeLift is the perfect solution for us. It's fast and quiet. And I love its simplicity!

Mr. Krysmanski, Ontario



17FEB2020

Stiltz HomeLifts

57 South Commerce Way #300
Bethlehem, PA 18017

(844) 4 STILTZ or (610) 443-2282
info@stiltzlifts.com

stiltzlifts.com

StiltzTM
The **homelift** company